

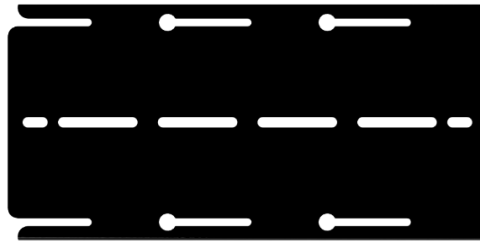

## Outdoor Housing Compatibility

- **STXL:** Sled Camera Bracket



## Camera Specifications (mm, [in.])

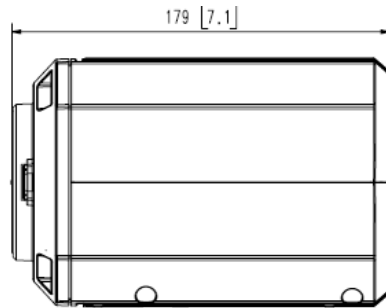
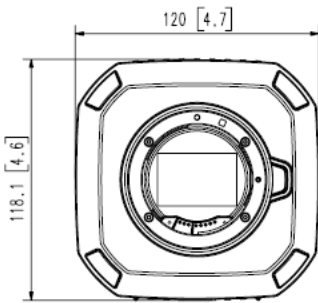

Power Input	<b>PoE+, 12VDC</b>
<b>Maximum Power Consumption</b>	30 W
Operating Temperatures	<b>-00°C to +45°C</b>
<b>Weight</b>	2.1 kg
Dimensions (L x W x H)	<b>179 x 120 x 118.1 (mm)</b>

## Housings Drawings (in.)

