

## Outdoor Housing Compatibility

- **STXL:** Sled Camera Bracket + Custom L Bracket (Made to Order)

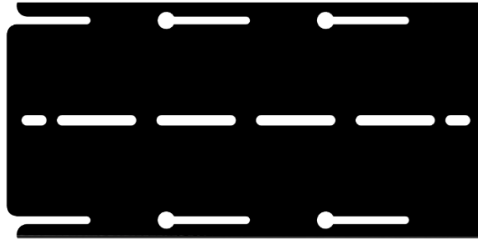

## Camera Specifications

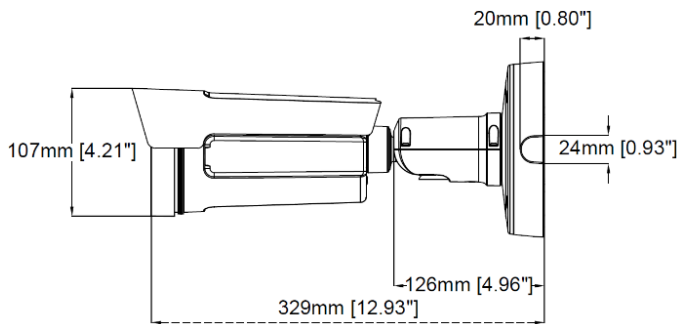

|                                  |                               |
|----------------------------------|-------------------------------|
| Power Input                      | <b>PoE, 8-28VDC, 20-24VAC</b> |
| <b>Maximum Power Consumption</b> | 13 W, 19VA                    |
| Operating Temperatures           | <b>-40°C to +60°C</b>         |
| <b>Weight</b>                    | 2.2 kg                        |
| Dimensions (L x W x H)           | <b>146 x 146 x 344 (mm)</b>   |

## Housings Drawings (in.)

