



Designed and manufactured by Dotworkz



STXL-CD

Installation Guide

IMPORTANT SAFEGUARDS

1. Read instructions - All the safety and operating instructions should be read before the unit is operated.
2. Retain instructions - The safety and operating instructions should be retained for future reference.
3. Heed Warnings - All warnings on the unit and in the operating instructions should be adhered to.
4. Follow instructions - All operating and user instructions should be followed.
5. Electrical Connections - Only a qualified electrician should make electrical connections.
6. Attachments - Do not use attachments not recommended by the product manufacturer as they may cause hazards.
7. Cable Runs- All cable runs must be within permissible distance.
8. Mounting - This unit must be properly and securely mounted to a supporting structure capable of sustaining the weight of the unit.

Accordingly:

- a. The installation should be made by a qualified installer.
- b. The installation shall be installed in compliance with the NEC and local regulations.
- c. Care should be exercised to select suitable hardware to install the unit, taking into account both the composition of the mounting surface and the weight of the unit.

Be sure to periodically examine the unit and the supporting structure to make sure that the integrity of the installation is intact. Failure to comply with the foregoing could result in the unit separating from the support structure and falling, with resultant damages or injury to anyone or anything struck by the falling unit.

UNPACKING

Unpack carefully. Electronic components can be damaged if improperly handled or dropped. If an item appears to have been damaged in shipment, replace it properly in its carton and notify the shipper.

Be sure to save:

1. The shipping carton and packaging material. They are the safest material in which to make future shipments of the equipment.
2. These Installation and Operating Instructions.

SERVICE

If technical support or service is needed, contact Sony at the following number:

Dotworkz Technical Support
8am-5pm
PST
(866) 575-4689

SAFETY PRECAUTIONS



CAUTION

**RISK OF ELECTRIC SHOCK
DO NOT OPEN**



CAUTION: TO REDUCE THE RISK OF ELECTRIC SHOCK, DO NOT REMOVE COVER (OR BACK). NO USER- SERVICEABLE PARTS INSIDE. REFER SERVICING TO QUALIFIED SERVICE PERSONNEL.



The lightning flash with an arrowhead symbol, within an equilateral triangle, is intended to alert the user to the presence of non-insulated "dangerous voltage" within the product's enclosure that may be of sufficient magnitude to constitute a risk to persons.

Este símbolo se piensa para alertar al usuario a la presencia del "voltaje peligroso no-aislado" dentro del recinto de los productos que puede ser un riesgo de choque eléctrico.

Ce symbole est prévu pour alerter l'utilisateur à la présence "de la tension dangereuse" non-isolée dans la clôture de produits qui peut être un risque de choc électrique.

Dieses Symbol soll den Benutzer zum Vorhandensein der nicht-Isolier "Gefährdungsspannung" innerhalb der Produkteinschließung alarmieren die eine Gefahr des elektrischen Schlages sein kann.

Este símbolo é pretendido alertar o usuário à presença "di tensão perigosa non-isolada" dentro do cerco dos produtos que pode ser um risco de choque elétrico.

Questo simbolo è inteso per avvertire l'utente alla presenza "di tensione pericolosa" non-isolata all'interno della recinzione dei prodotti che può essere un rischio di scossa elettrica.



The exclamation point within an equilateral triangle is intended to alert the user to presence of important operating and maintenance (servicing) instructions in the literature accompanying the appliance.

Este símbolo del punto del exclamation se piensa para alertar al usuario a la presencia de instrucciones importantes en la literatura que acompaña la aplicación.

Ce symbole de point d'exclamation est prévu pour alerter l'utilisateur à la présence des instructions importantes dans la littérature accompagnant l'appareil.

Dieses Ausruf Punktsymbol soll den Benutzer zum Vorhandensein de wichtigen Anweisungen in der Literatur alarmieren, die das Gerät begleitet.

Este símbolo do ponto do exclamation é pretendido alertar o usuário à presença de instruções importantes na literatura que acompanha o dispositivo.

Questo simbolo del punto del exclamation è inteso per avvertire l'utente alla presenza delle istruzioni importanti nella letteratura che accompagna l'apparecchio.

Contents of Box

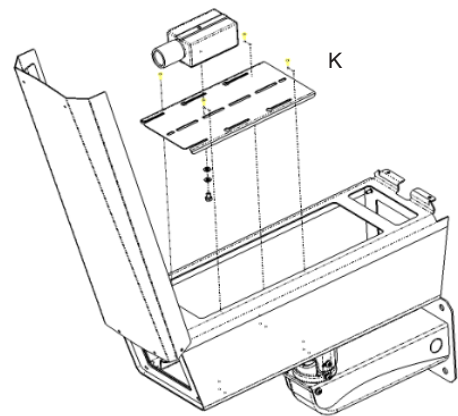
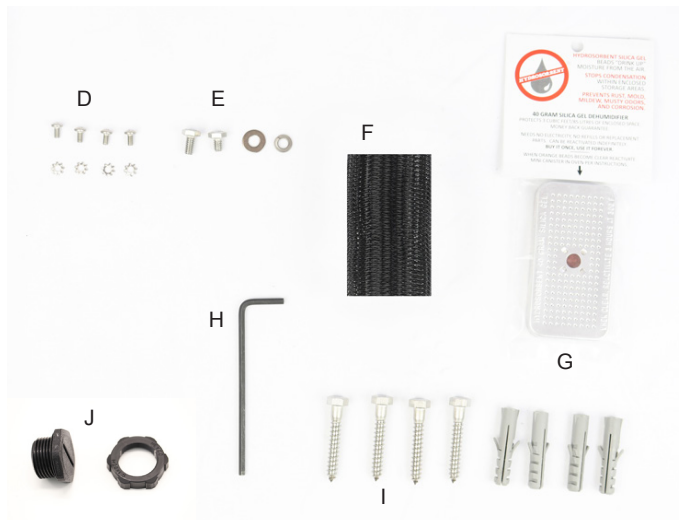
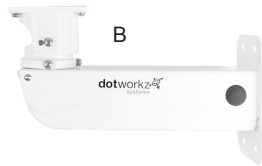

- A. Enclosure/housing
- B. Wall mount arm
- C. Outdoor power supply (Can be mounted inside wall mount arm)
- D. Power supply mounting screws and washers
- E. Camera mounting bolts and washers
- F. Cable management sleeve inside wall mount arm
- G. Rechargeable desiccant humidity removal pack
- H. Allen wrench tool for adjusting knuckle wall mount arm
- I. Wall mount screws and anchors
- J. Threaded locknut
- K. Camera sled pre-installed

Tools needed

1. Phillips screwdriver
2. Socket wrench
3. Electronics size flat screwdriver

1



Loosen 2 screws on the top back side of the housing.

2



Loosen the lockable latch on the back side of the housing.

3



Slowly open the top hatch and be careful not to let it drop.

4



Remove the 4 screws on the camera mounting plate and set aside.

5



Note: If your lens needs room to zoom in and out, make sure you align the max zoom position with the front of the camera mounting plate.



Align the front of the lens with the front of the camera mounting plate.

6

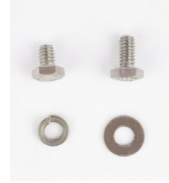

Carefully flip the camera and plate upside to keep position of camera on mounting plate. Choose the camera mounting bolt that best fits your camera and tighten firmly but do not over tighten.

7



Locate the 4 camera mounting plate screws and loosely fasten mounting plate to housing.

8



Check to make sure lens is not touching the glass. If it is, simply slide the camera mounting plate backward. Tighten screws to secure position.

9



Close the hatch to the housing and secure it with the lockable latch. Flip housing upside down.

10

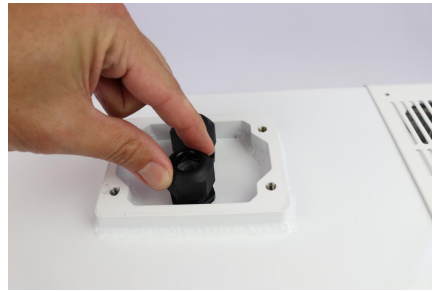

Remove cable gland nut to provide power, network, or other cables needed in the housing.

11

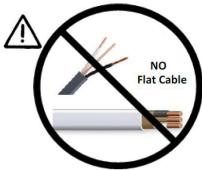
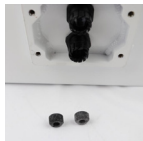
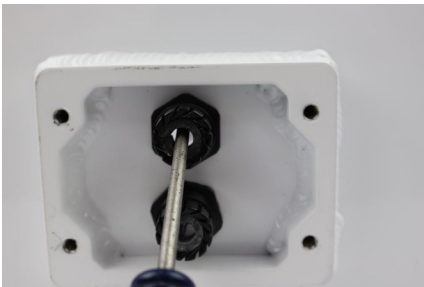

NO
Flat Cable

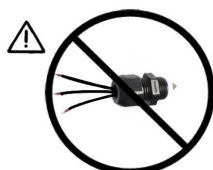

Carefully remove cable gland rubber cable sealer with a screw drive so as not to damage it. Remember which direction the rubber gland fits in the cable gland.

12



With the smaller Allen wrench (provided) loose the left and right bolts that allow the arm to swim. 1 full turn each should do it.

13



With the larger Allen wrench (provided) remove the bolt on the bottom of the arm that allows it to be opened.

14



Run necessary cables (power, network, etc...) through arm and arm knuckle. See Appendix A if mounting a power supply inside the arm.

15

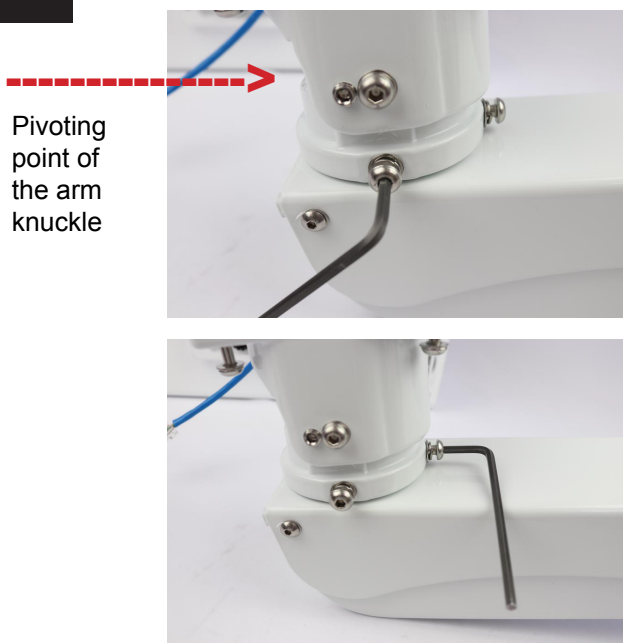

Pivoting point of the arm knuckle

Fit the arm knuckle onto the arm with the pivoting point of the arm knuckle towards the front of the arm. With the larger Allen wrench (provided) tighten the 3 bolts.

16

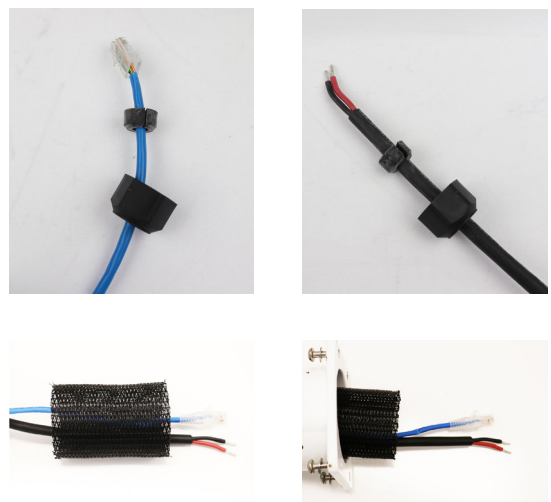

First, add the cable gland nut to your network or power cable. Second, add the cable gland rubber seal with the taper end away from the end of the cable. Lastly, add the black mesh sleeve to cables.

17

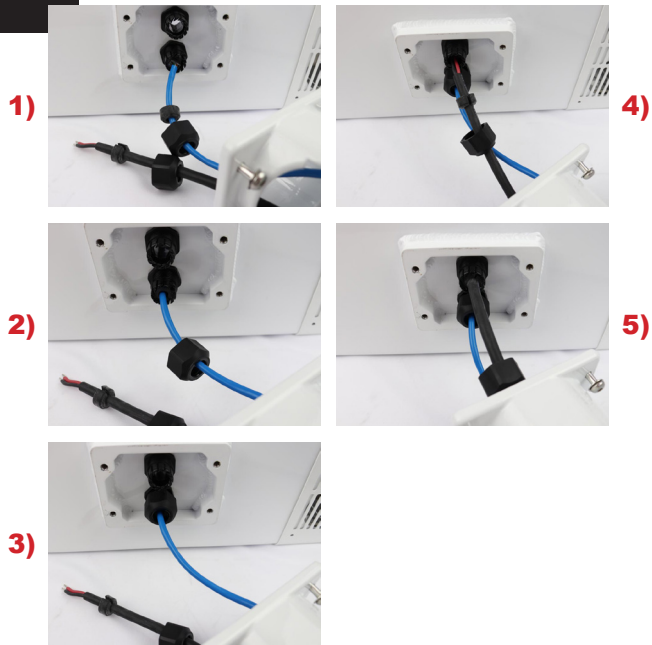

Pass the cable end through the cable gland port on the housing. Carefully insert the cable gland seal and then very loosely screw on the cable gland nut.

18



Before mounting the other side of the arm knuckle to the housing, completely hand tighten the cable glands.

19



Using the larger Allen wrench (provided) tighten the 4 bolts from the arm knuckle to the housing.

20



Flip the camera housing with arm upright so you can have access to camera inside.

21

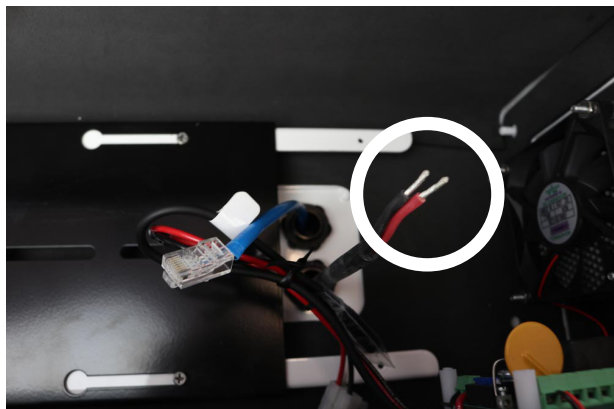

Open the lid to the housing. Locate the power cable from the cable gland port and the 12V power connector.

22

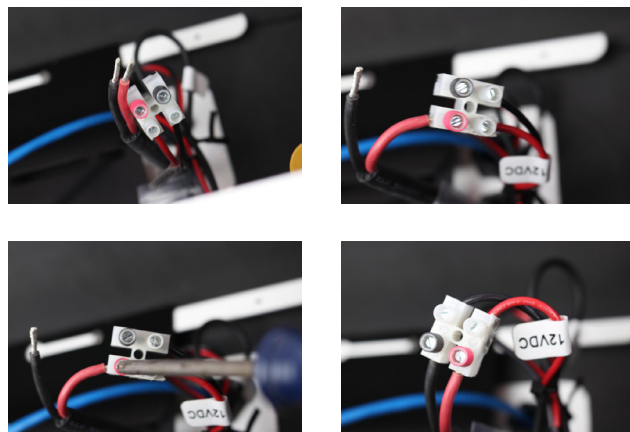

Insert the red cable into the red side of the 12V power connector. Tighten with a small flat screw driver. Repeat for black cable.

23

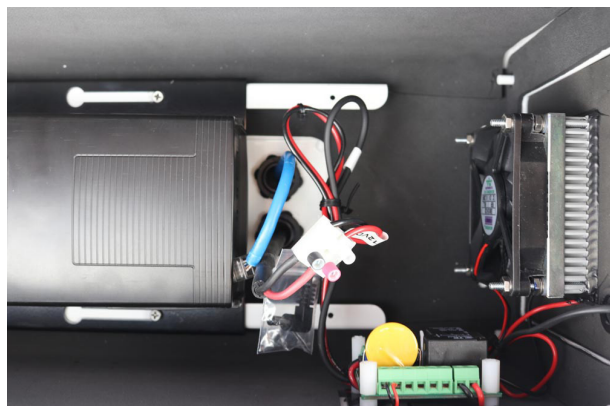

Connect the network and power cable to the camera.

24



Place the humidity removal pack (included) near the back of the housing on the insulation pad.
* Reminder: Recharge the desiccant humidity removal pack when needed per package instructions.

25



For proper closure please follow these steps.

26



Use the latch to pull the lid down.

27



Once latch is pulled down in this position. Use a screwdriver to tighten the two top fasteners.

28



This will ensure proper seal.

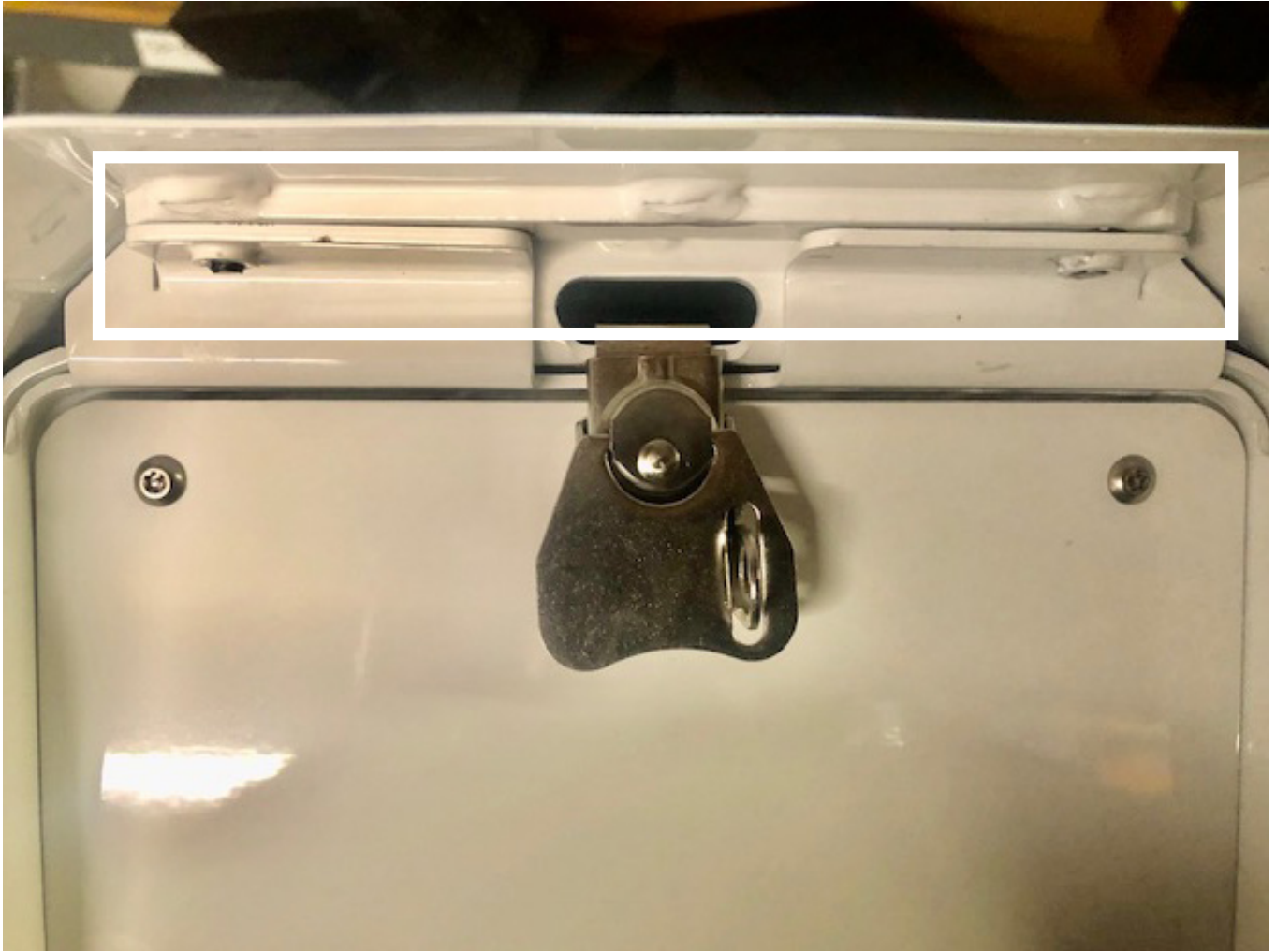

Above is a properly sealed lid.

Appendix A: Mounting Power Supply Inside Arm

1)



Open arm and push cable (the end with the single black and single red cable) through the knuckle arm hole.

2)



Position the power supply in the arm so that the holes for the screws align.

3)



Find 4 Philips head screws and tightening washers (included). Fasten the power supply to the arm.

4)



Push the other end of the power supply cable through the back square hole of the arm so the arm can close without damaging the cables.

5)



Replace the bolt with the larger Allen wrench to complete close the arm.

LIMITED WARRANTY

DOTWORKZ, INC. PRODUCTS

DOTWORKZ SYSTEMS INC. Warrants this Product to be free from defects in material or workmanship, as follows:

PRODUCT CATEGORY	PARTS	LABOR
All Enclosures and Electronics	One (1) Year	One (1) Year
Power Supplies	One (1) Year	One (1) Year
Accessory Brackets	One (1) Year	One (1) Year

During the warranty period, to repair the product the purchaser will deliver it to Dotworkz Systems Inc. San Diego, CA or return the defective product, freight prepaid. The product to be repaired is to be returned in either its original carton or a similar package presenting an equal degree of protection with a Return Materials Authorization number displayed on the outer box or packing slip. To obtain RMA # you must contact our Technical Support Team at 866-575-4689. Dotworkz Systems will return the repaired Product, freight paid. Dotworkz Systems is not obligated to provide purchaser with a substitute unit during the warranty period or at any time. After the applicable warranty period, purchaser must pay all labor and/or parts and shipping charges.

The limited warranty stated in these product instructions is subject to all of the following terms and conditions:

- 1. NOTIFICATION OF CLAIMS: WARRANTY SERVICE:** If purchaser believes that the product is defective in material or workmanship, then a written notice with an explanation of the claim shall be given promptly by purchaser to Dotworkz Systems but all claims for warranty service must be made within the warranty period. If after investigation Dotworkz Systems determines that the reported problem was not covered by the warranty, purchaser shall pay Dotworkz Systems for the cost of investigating the problem at its then prevailing per incident billable rate. No repair or replacement of any product or part thereof shall extend the warranty period as to the entire product. The specific warranty on the repaired part only shall be in effect for a period of ninety (90) days following the repair or replacement of that part or the remaining period of the product parts warranty, whichever is greater.
- 2. EXCLUSIVE REMEDY: ACCEPTANCE:** Purchaser's exclusive remedy and Dotworkz Systems sole obligation is to supply (or pay for) all labor necessary to repair any product found to be defective within the warranty period and to supply, at no extra charge, new or rebuilt replacements for defective parts
- 3. EXCEPTIONS TO LIMITED WARRANTY:** Dotworkz Systems shall have no liability or obligation to purchaser with respect to any product requiring service during the warranty period which is subjected to any of the following: abuse, improper use, negligence, accidents, lightning damage or other acts of God (i.e., hurricanes, earthquakes), modification, failure of the end-user to follow the directions outlined in the product instructions, failure of the end-user to follow the maintenance procedures written and recommended in the product instructions and service manual, or recommended by the International Security Industry Organization. Furthermore, Dotworkz Systems shall have no liability where a schedule is specified for regular replacement, maintenance or cleaning of certain parts (based on usage) that the end-user has failed to abide to such schedule; attempted repair by non-qualified personnel; operation of the Product outside of the published environmental and electrical parameters; if such Product's original identification (trademark, serial number) markings have been defaced, altered, or removed. Dotworkz Systems excludes from warranty coverage products sold AS IS and/or WITH ALL FAULTS and excludes used Products which have not been sold by Dotworkz Systems to the Purchaser. All software and accompanying documentation furnished with, or as part of the Product is furnished "AS IS" (i.e., without any warranty of any kind), except where expressly provided otherwise in any documentation or license agreement furnished with the Product.
- 4. PROOF OF PURCHASE:** The purchaser's dated bill of sale must be retained as evidence of the date of purchase and to establish warranty eligibility.

DISCLAIMER OF WARRANTY EXCEPT FOR THE FOREGOING WARRANTIES, DOTWORKZ SYSTEMS HEREBY DISCLAIMS AND EXCLUDES ALL OTHER WARRANTIES, EXPRESSED OR IMPLIED, INCLUDING, BUT NOT LIMITED TO ANY AND/OR ALL IMPLIED WARRANTIES OF MERCHANTABILITY, FITNESS FOR A PARTICULAR PURPOSE AND/OR ANY WARRANTY WITH REGARD TO ANY CLAIM OF INFRINGEMENT THAT MAY BE PROVIDED IN SECTION 2-312(3) OF THE UNIFORM COMMERCIAL CODE AND/OR IN ANY OTHER COMPARABLE STATE STATUTE. DOTWORKZ SYSTEMS HEREBY DISCLAIMS ANY REPRESENTATIONS OR WARRANTY THAT THE PRODUCT IS COMPATIBLE WITH ANY COMBINATION OF NON-V1DEQLARM PRODUCTS OR NON-DOTWORKZ SYSTEMS RECOMMENDED PRODUCTS THAT THE PURCHASER CHOOSES TO CONNECT TO THE PRODUCT.

LIMITATION OF LIABILITY THE LIABILITY OF DOTWORKZ SYSTEMS, IF ANY, AND PURCHASER'S SOLE AND EXCLUSIVE REMEDY FOR DAMAGES FOR ANY CLAIM OF ANY KIND WHATSOEVER, REGARDLESS OF THE LEGAL THEORY AND WHETHER ARISING IN TORT OR CONTRACT SHALL NOT BE GREATER THAN THE ACTUAL PURCHASE PRICE OF THE PRODUCT WITH RESPECT TO WHICH SUCH CLAIM IS MADE. IN NO EVENT SHALL DOTWORKZ SYSTEMS BE LIABLE TO PURCHASER FOR ANY SPECIAL, INDIRECT, INCIDENTAL, OR CONSEQUENTIAL DAMAGES OF ANY KIND INCLUDING BUT NOT LIMITED TO COMPENSATION, REIMBURSEMENT OR DAMAGES ON ACCOUNT OF THE LOSS OF PRESENT OR PROSPECTIVE PROFITS, OR FOR ANY OTHER REASON WHATSOEVER.