

## Versatile, Virtually Indestructible and Ready for the Extreme

Not just a camera enclosure but an engineered outdoor housing system that is designed to expand all indoor camera models into complete rugged outdoor system solutions.

Virtually Indestructible: We produce the world's toughest enclosures. They will not corrode, rust, leak and have proven to withstand a whole world of abuse.

No matter the climate we take outdoor temperature protection very seriously: Extreme Hot climates, Cold climates, Marine and everywhere in between.



- Universal input voltages options: 24 VAC/VDC, 110 - 220 VAC
- 12 VDC and 24 V camera and component power
- Easier, faster installation process - less time
- Works with most camera brands and models

innovative

## D3-HB-MVP: Dotworkz D3 Heater Blower Camera Enclosure with MVP



### Description:

The D3-HB-MVP is compatible with virtually every IP and analog PTZ camera on the market, now with MVP to work with all input and camera voltages. Made from impact resistant Polycarbonate Thermal Plastic.

The ultimate barrier to protect camera and other sensitive components from harsh environments. Heater & Blower is designed for weather conditions ranging from freezing to hot climates.

### Specs:

Operating Temperature (Absolute/Rec.):

-25° to 140° F (-32° C to 60° C)

0° to 120° F (-17° C to 49° C)

Power Consumption:

2 amps @ 115 VAC typical at full load

MVP Input Power Source Options:

24VAC/VDC 110 VAC, or 220 VAC

MVP Output Options for Camera Power:

12VDC, 24V

Internal Power Available for Camera:

2.25 amps @ 12 VDC on typical model

Shipping: 22" x 13" x 16" - 13 lbs (5.9 Kg)



### Features:

- Thermostatically controlled Heater Blower System
- Virtually indestructible Polycarbonate Thermal Plastic alloy
- Designed to work with all brands of IP and analog PTZ cameras
- Internal bracket included for perfect fit for PTZ, megapixel or mini domes
- Switchable upper and lower camera mounting locations for maximum versatility and internal storage space
- Internal mounting space for: routers, cell networks, hard drives, UPS, WiMAX, mesh hardware, etc
- IP66 rated against dust, water and salt water air
- IP68 water proof connection ports included
- 60% bigger then our D2 models perfect for adding Wireless, camera and NVR as a single install system

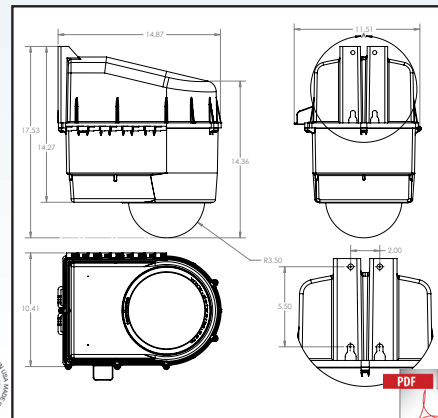

remote video solutions

www.dotworkz.com 866.575.4689

