

### Overview

The Dotworkz HD12 product line consists of large scale, outdoor housings that are designed to protect broadcast quality PTZ cameras from the harshest environmental conditions.

With combined heater/blower and CoolDome™ technology, the HD12-CD-HB is designed to exceed IP66/NEMA 4X standards for ingress protection, providing excellent protection from water, dust, corrosion, and insects.

### Key Features

- Power conversion from 120 VAC standards to 12 VDC input for HD cameras and temperature control electronics
- 4 cable egress locations with various gland options for multiple reliably sealed connections
- Several mounting options from pendant mounted to wall mounted to pole mounted (shown on right)
- Extended temperature range with both active heating and active cooling technology in one complete system
- Large dome lens maximizes viewing angles in all directions

### Applications

Use the HD12 system with broadcast quality cameras at large venues for viewing sports, concerts, and fan reactions with a variety of mounting options available from Dotworkz.

HD12 housings are ideal for weather stations, allowing viewers to see clear imagery in environmentally challenging situations.

### Size & Weight

Product Number	Product Weight	Product Dimensions
HD12-CD-HB	32 lbs.	18.7" x 19.7" x 27.4"

### Product Attributes

- Din Rail internal mounting options for additional hardware and cable management
- Sealed from outside air, dust, water, insects, salt fog, and other conditions



*Pole Mounted HD12-CD-HB with example broadcast camera installed*

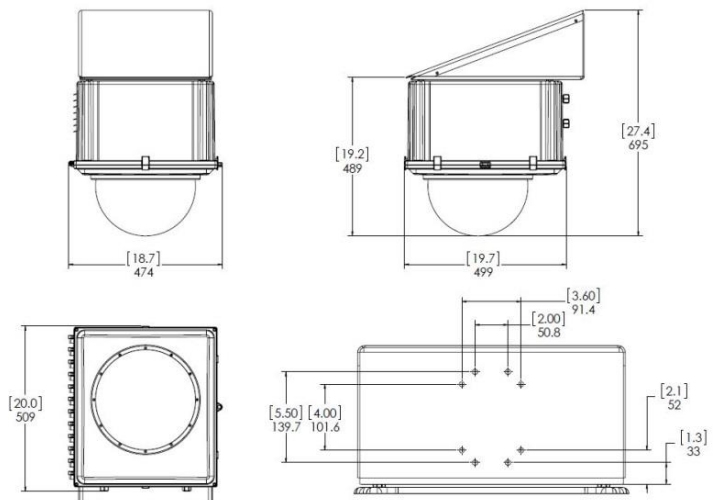

\*Product specifications are subject to change without notice